

TEQOIA

EGG HANDLING WITH VISION

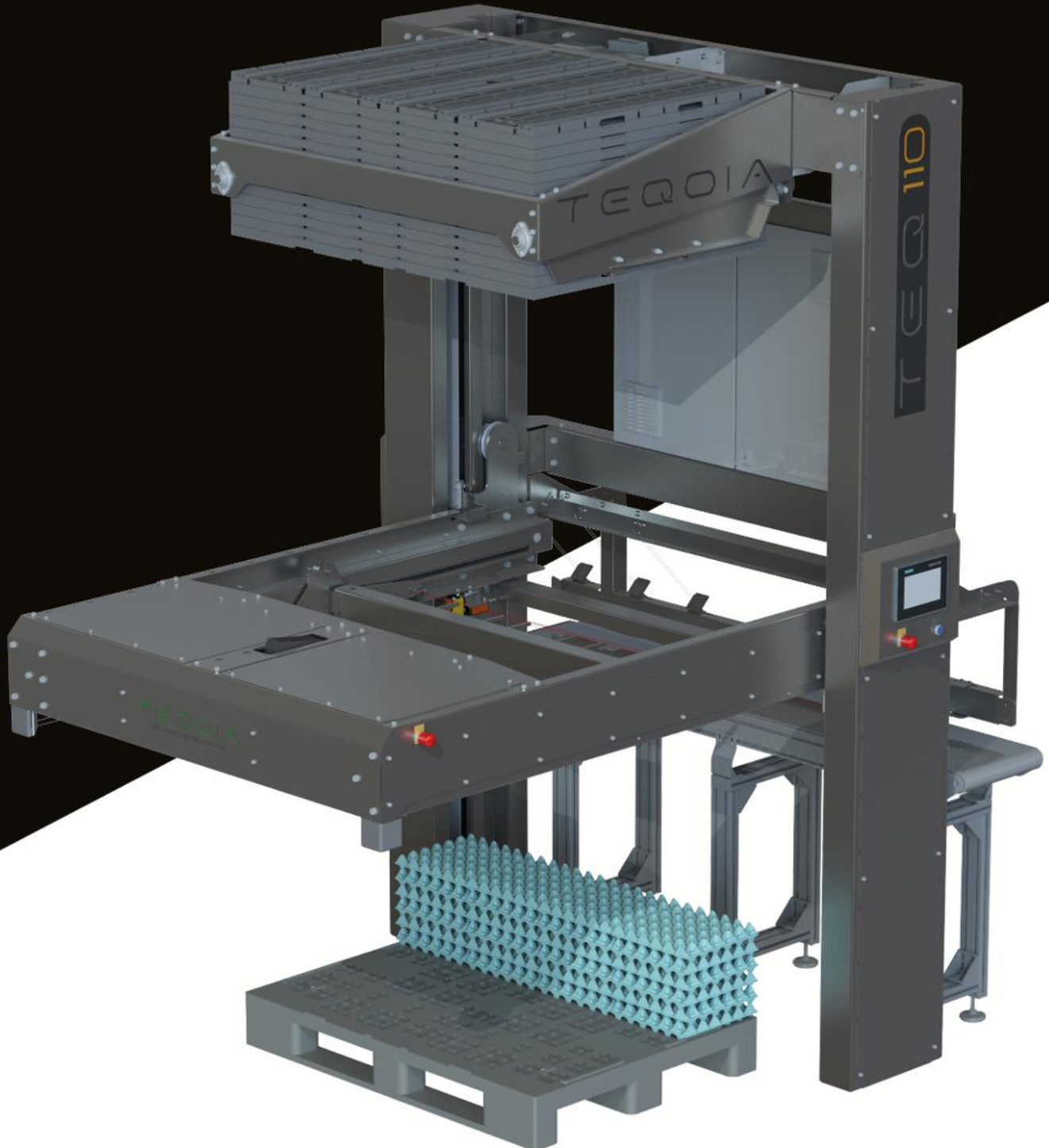

TEQ 110: Palletizer

The most innovative, compact, and reliable palletizer.
Dutch Engineering, Global Support.

TEQOIA

EGG HANDLING WITH VISION

Why us?

TEQOIA is a Dutch machine builder and system integrator in the egg industry with a clear vision for the future. Driven by innovation, passion, and craftsmanship, we develop smart and reliable solutions for our customers that make production processes more efficient, sustainable, and future-proof.

Our machines are delivered worldwide and supported with prompt professional service wherever you are located. With a strong focus on technology, detail, and collaboration, we work together with our customers to build the egg industry of tomorrow.

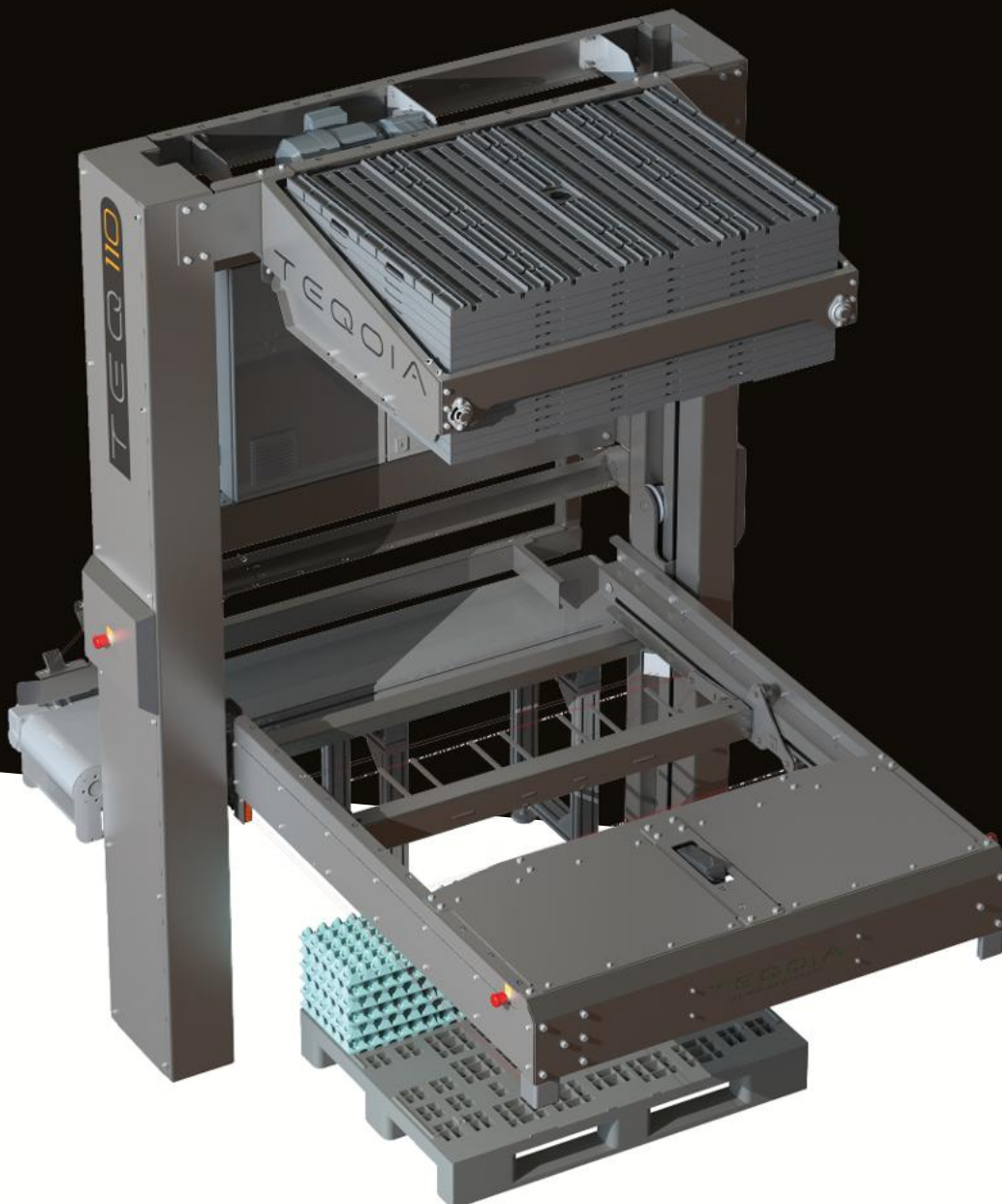

Compact palletizing solution – Maximum efficiency

The TEQ110 combines a compact footprint with maximum flexibility within the production line. Thanks to its intelligent design, the pallet can be accessed and moved out from three sides, ensuring efficient and practical operation in a wide range of production environments.

The machine is fully constructed from high-quality stainless steel and designed for reliable continuous operation. Every step within the process is monitored and scanned. Thanks to the smart scanning function, it is also possible to load and scan an unfinished pallet, after which, the TEQ110 automatically resumes the process.

Key features & specifications

- ✓ **Small footprint**
Compact design requiring minimal floor space.
- ✓ **Pallet accessible from three sides**
Thanks to the two-column construction, the pallet remains easily accessible and can be moved out from any of three sides for maximum flexibility.
- ✓ **Clamping on both sides of the dividers**
The dual-side clamping system allows storage capacity for up to 40 dividers.
- ✓ **Fully stainless steel construction**
The TEQ110 Palletizer is fully constructed from stainless steel and built using A-grade materials and components.
- ✓ **Compatible with any tray stacker**
Flexible in application and easy to integrate with any tray stacker.
- ✓ **Reliable and user-friendly**
Designed for continuous operation, easy cleaning, and excellent accessibility for maintenance.
- ✓ **Dutch engineering**
Developed through Dutch engineering expertise and successfully installed in a wide range of production environments worldwide.

20 DIVIDERS IN THE MACHINE HEIGHT,
UP TO 40 IN TOTAL

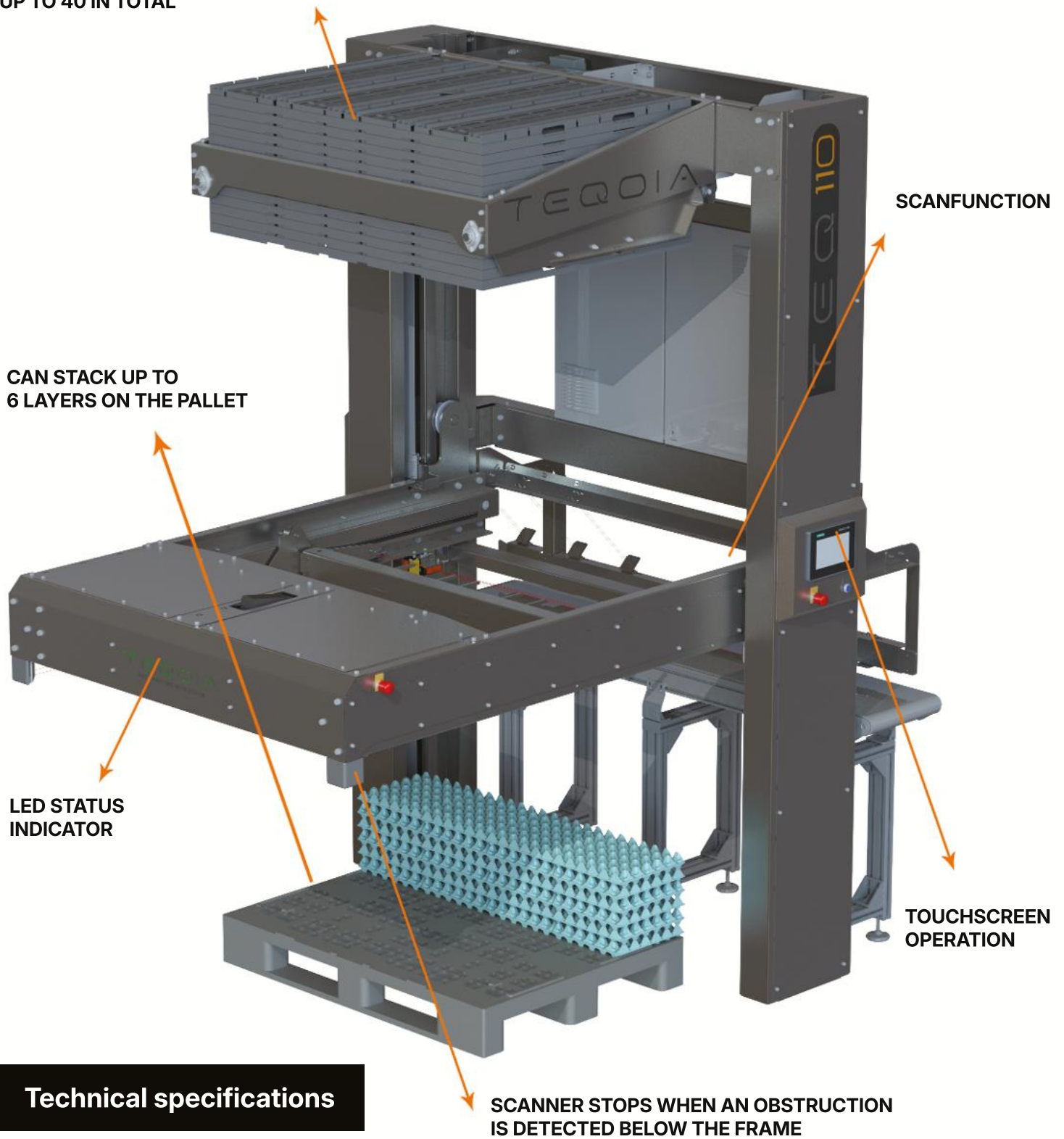

Technical specifications

Dimensions:	8.21 × 6.86 × 9.55 ft (2503 × 2092 × 2910 mm)	Dividers:	40 dividers total
Weight:	550 kg	Compressed Air:	Not needed
Material:	RVS / stainless steel	Cleaning:	Downwashable
Capacity:	40,000 eggs per hour	Safety:	Safety stop under moving frame
Connection:	230 V - 50/60 Hz	Coupling:	Can be connected to any tray stacker
Operating temperature:	5°C - 38°C (41°F - 100°F)	Scan Function:	Scans every action and can continue with a half pallet
		Pallet Position:	Pallet can be accessed/removed from three sides
		Protection rating:	IP65

TEQOIA

EGG HANDLING WITH VISION

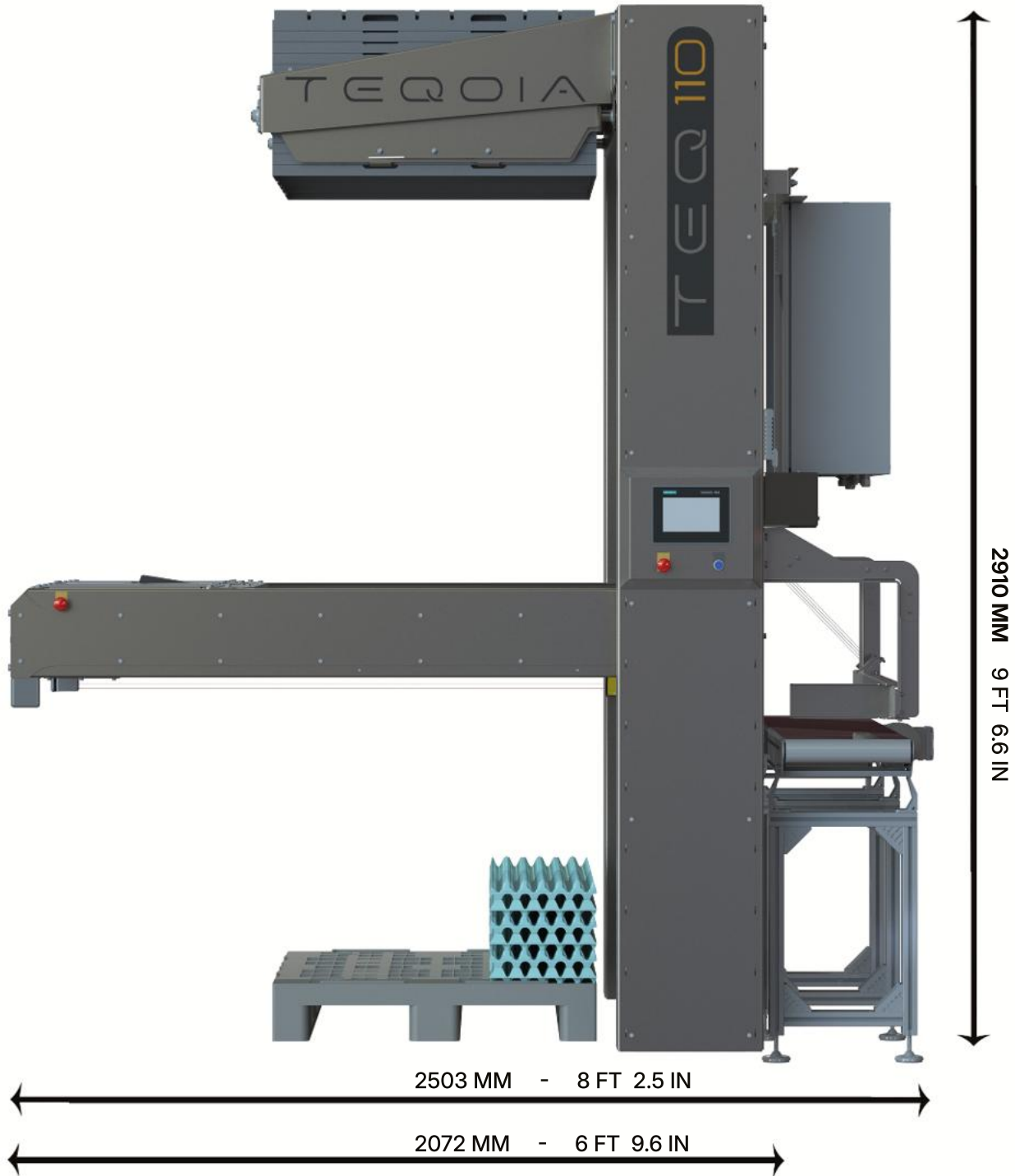

TEQOIA.COM

Technical dimensions – front view

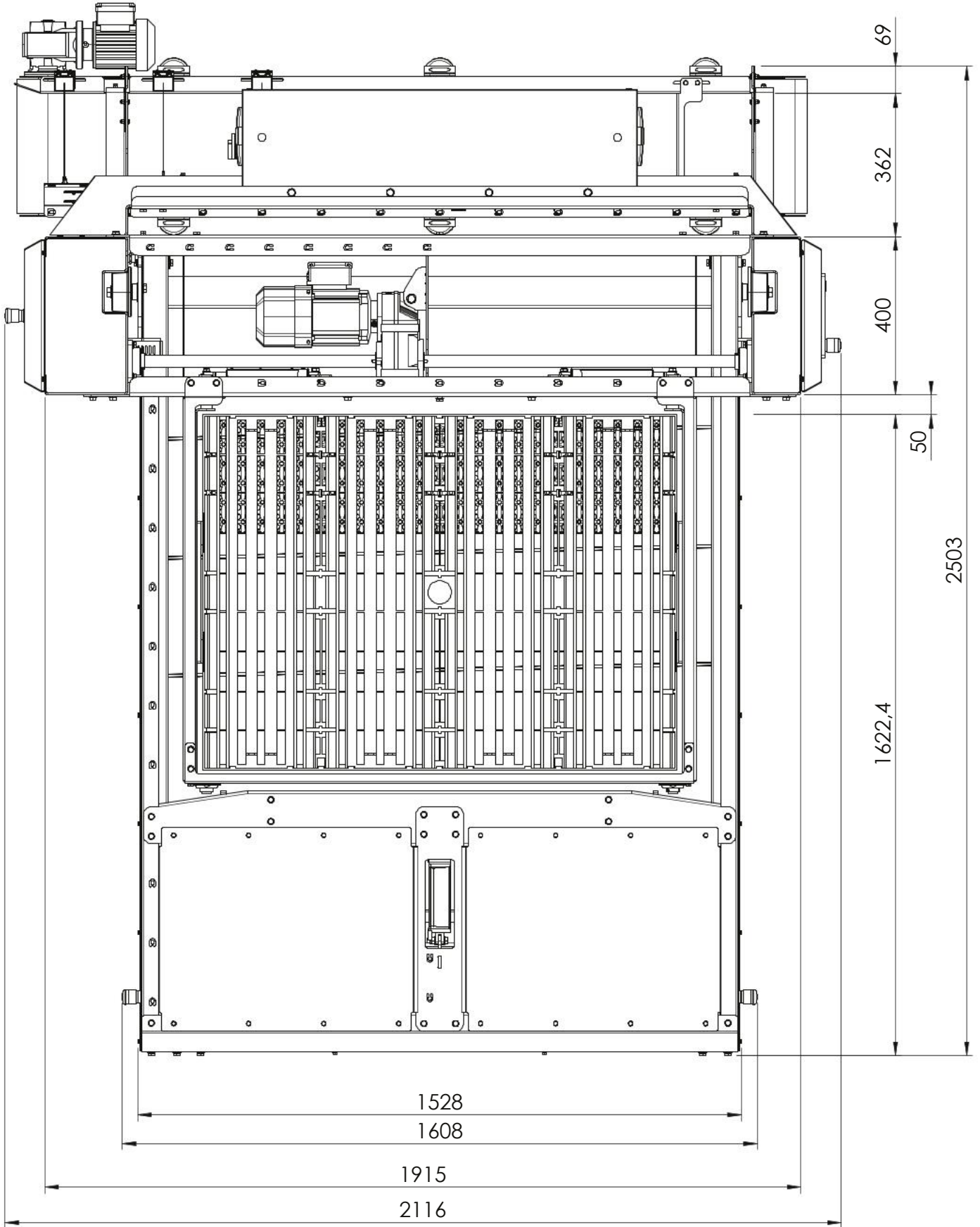

Technical dimensions – side view

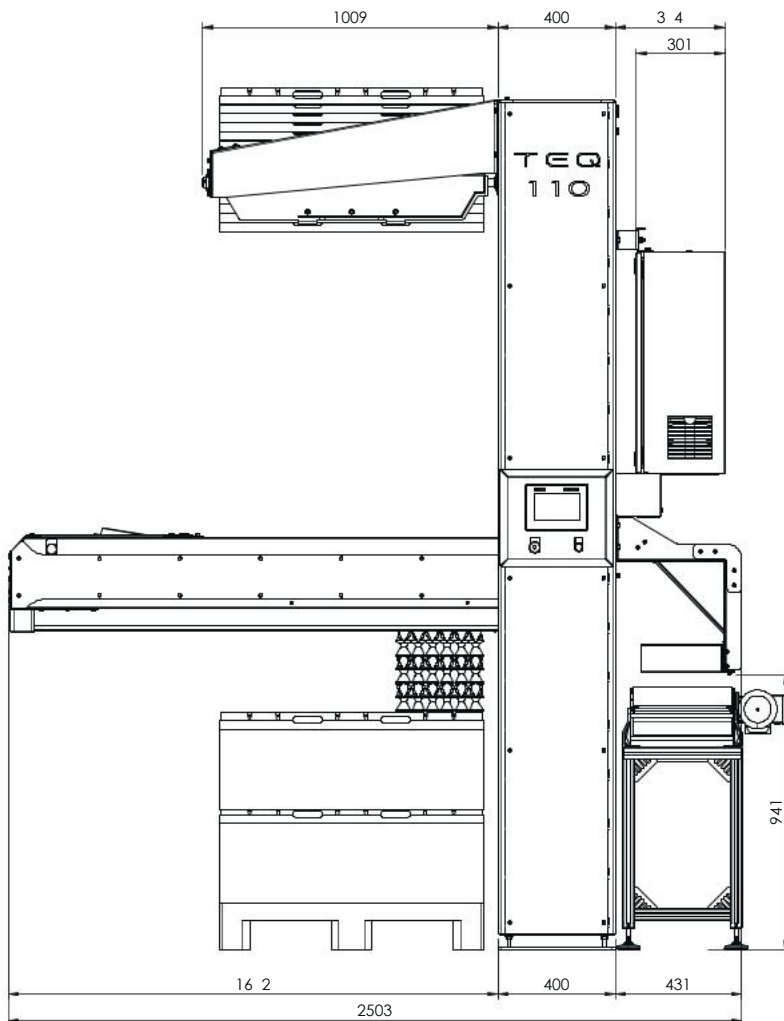
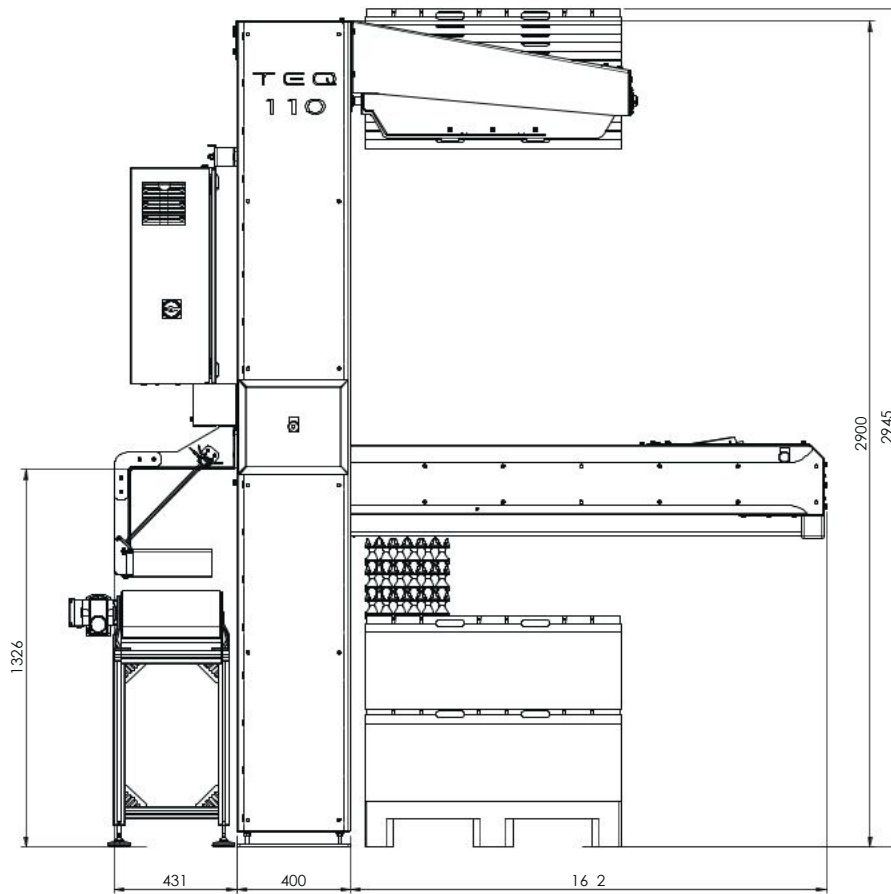

Learn more about our solutions:



TEQOIA.COM

Custom Engineering & Global Partnership

- ✓ **Conveyor Systems:**
Complete conveyor solutions for efficient product flow.
- ✓ **Vision & Safety:**
Advanced systems for safe, accessible operation.
- ✓ **Pushers & Stoppers:**
Controlled product handling and optimized flow.
- ✓ **Service & Installation:**
Global service and professional installation.
- ✓ **Spare Parts & Support:**
Reliable spare parts for maximum uptime.



+31 (0) 342 745 036
www.teqoia.com
solutions@teqoia.com

TEQOIA
EGG HANDLING WITH VISION

TEQOIA B.V.

Verlengde Parallelweg 4-07
3771 LP Barneveld, The Netherlands